

FOOT  
BRIDGE  
2017 Berlin



**THE OBSERVATION POINT "WOLKENHAIN"  
BRIDGE AS WELL AS TOWER:  
A NEW LANDMARK IN BERLIN**

klähne  ingenieure



## Content

1. Introduction
2. Structure description
3. Design procedure
4. Design of Connections
5. Manufacturing and assembly of the structure
6. Discussion and Conclusions

# 1. Introduction

IGA is the International Garden Exhibition

IGA takes place in Berlin from 13. April 2017 bis 15. Oktober 2017





# 1. Introduction

IGA park has an area of 60 hectares

Inside the park one can find some engineering structures:

- footbridges,
- ropeway,
- and also the observation point called “Wolkenhain”





# 1. Introduction

## Timeline:

2008 Berliner Senat applies for IGA Berlin 2017 (Venue former Airport Tempelhof)

2009 Submission of application by german national garden show corporation mbH (DBG)

2010 Founding of IGA Berlin 2017 GmbH

2012 Relocation of IGA Berlin 2017 to Marzahn-Hellersdorf

2013 International Landscape architecture competition

2014 Beginning of construction work for IGA 2017

## Main requirements of frame concept of competition:

- further development of Kienberg to ecological city forest with sport possibilities and the projects of nature education in Wuhletal,
- the “Gardens of the World” (already the biggest attraction of the district) should be double extended only for this event,



# 1. Introduction

The main point of competition was to develop an tower at the top of the hill “Kienberg”, which:

- should be walkable,
- should be a landmark in the East part of Berlin,
- ensures the best views on the city

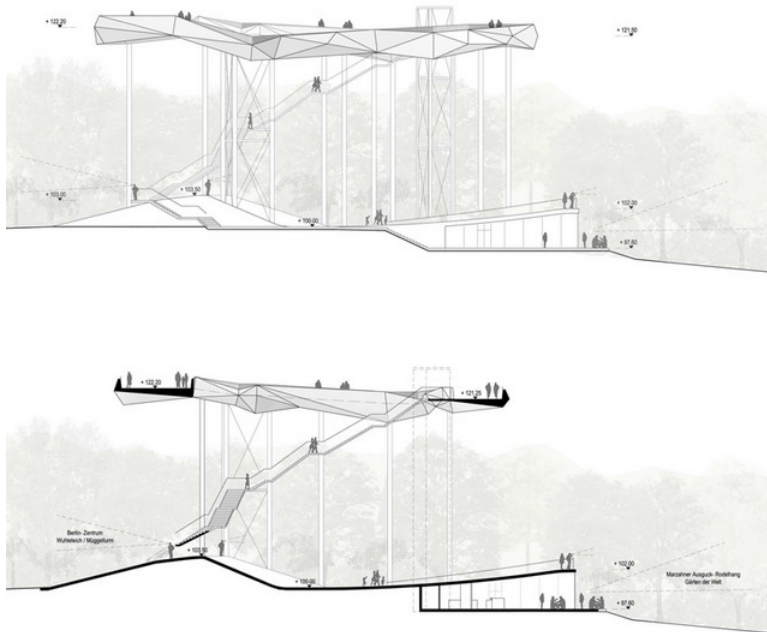

© geskes.hack Landschaftsarchitekten, VIC Brücken und Ingenieurbau, Kolb Ripke Architekten



# 1. Introduction

Results of the Competition of 25 Participants:

1. Price: **geskes.hack Landschaftsarchitekten GmbH, Berlin (Landscape Architects)**  
**VIC Planen und Beraten GmbH, Potsdam (Civil Engineers)**  
**Kolb Ripke Architekten Planungsgesellschaft mbH, Berlin (Architects)**  
**werk3 architekturvisualisierungen, Berlin (Visualisation)**
  2. Price: Panorama Landschaftsarchitektur, Berlin (Landscape Architects)  
SFB | Saradshow Fishedick Berlin Bauingenieure GmbH, Berlin (Civil Engineers)  
UT Architects, Berlin (Architects)
  3. Price: Atelier LOIDL, Berlin (Landscape Architects)  
BPR Dr. Schäpertöns Consult GmbH & Co.KG, Berlin (Civil Engineers)  
Wessendorf Architektur Städtebau, Berlin (Architects)
- Recognition: POLA, Berlin (Landscape Architects)  
Klähne Beratende Ingenieure im Bauwesen GmbH, Berlin (Civil Engineers)  
AFF Architekten, Berlin (Architects)

Internationaler  
Landschaftsarchitektonischer  
Wettbewerb IGA Berlin 2017

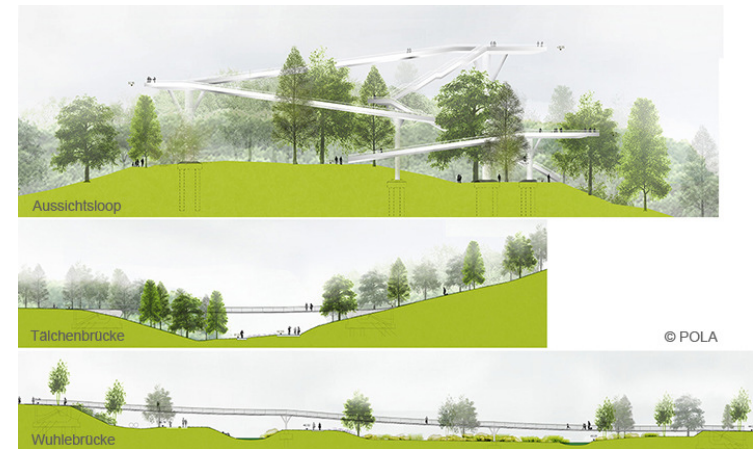
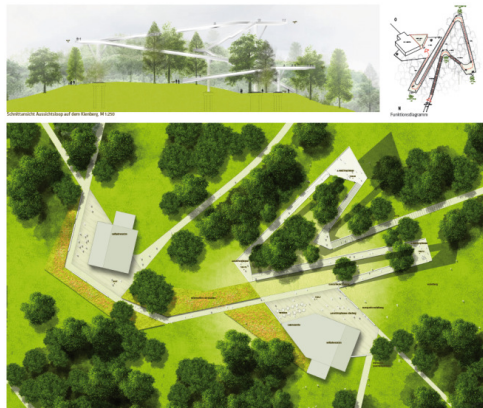

# 1. Introduction

## Essential structures



Wolkenhain

Ropeway



Whale – water playground



Visitor Service



Wooden Horses



Wuhletal Bridge



Little valley Bridges





## 2. Structure description

- The structure of “Wolkenhain” is a polygonal space structure.
- It is supported on a few very slender columns and is equipped with stairs and lift tower.

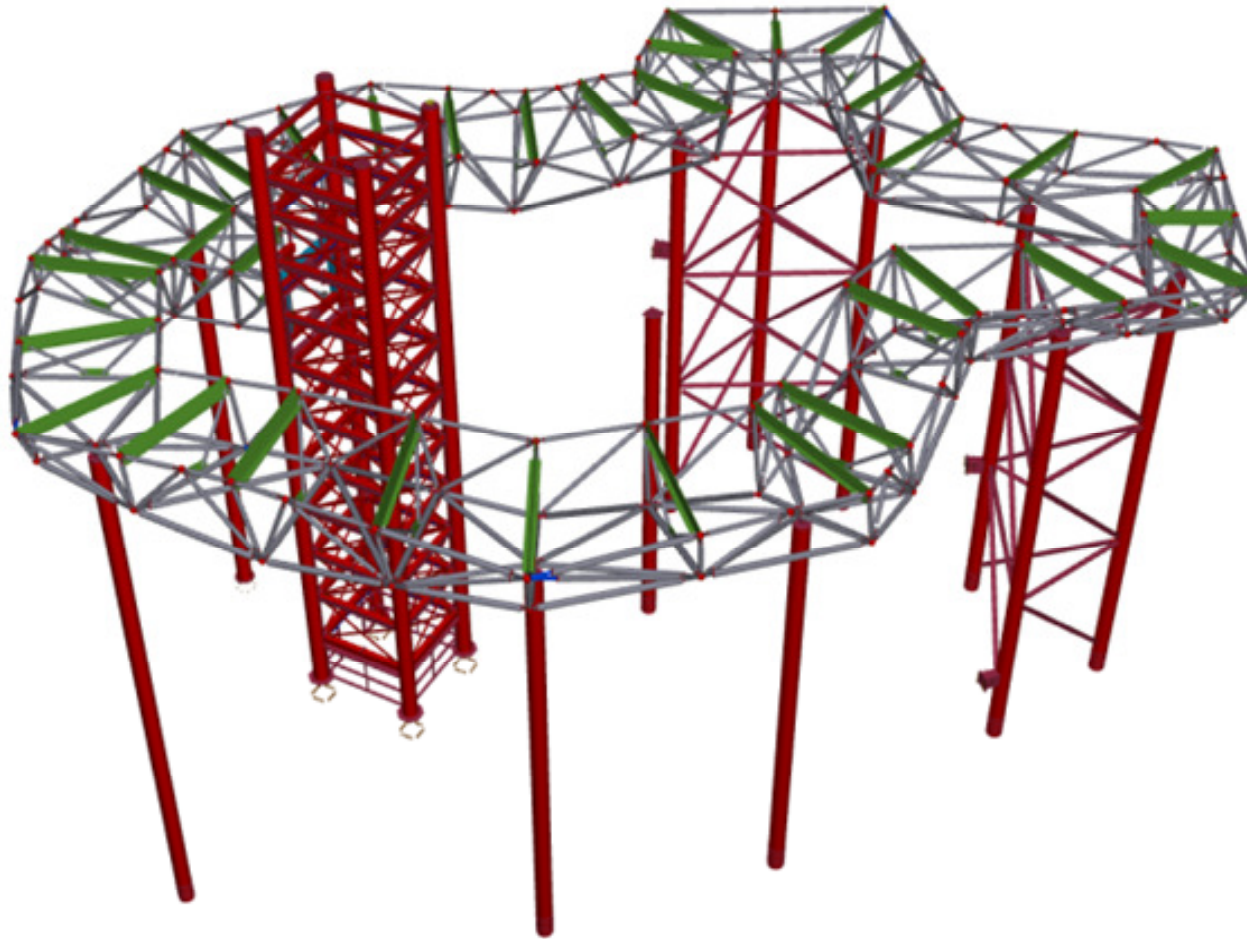

## 2. Structure description

- The connections with the columns are realized by using special transverse frames, placed directly over these columns.

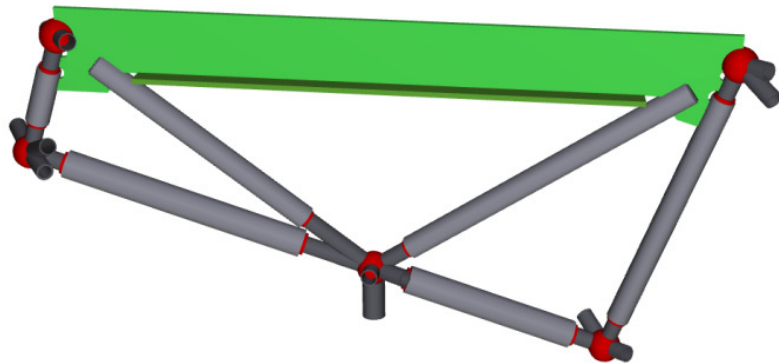

- The remaining transverse frames are used to give the structure its own specific architectural appearance.
- About 34 transverse frames were used to build this construction.
- Everyone of it has its own unique geometry and is not repeated in any section of the structure.

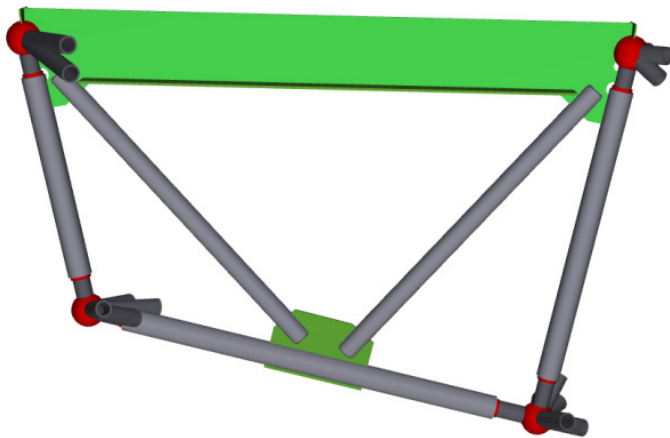



## 2. Structure description

- The transverse frames are joined with numerous circular hollow profiles with dimensions from 114,3 x 6,3 mm to 177,8 x 16 mm
- The deck is built as an orthotropic plate



## 2. Structure description

- The connection between the single bars was the most difficult task to solve in the execution planning process.
- Because of the very complicated geometry of the structure it was not possible to use typical solutions for the joints of the spatial trusses.
- It was decided to connect the bars using solid steel balls with diameter of 200 mm.
- About 160 of those connections were needed to build this structure.

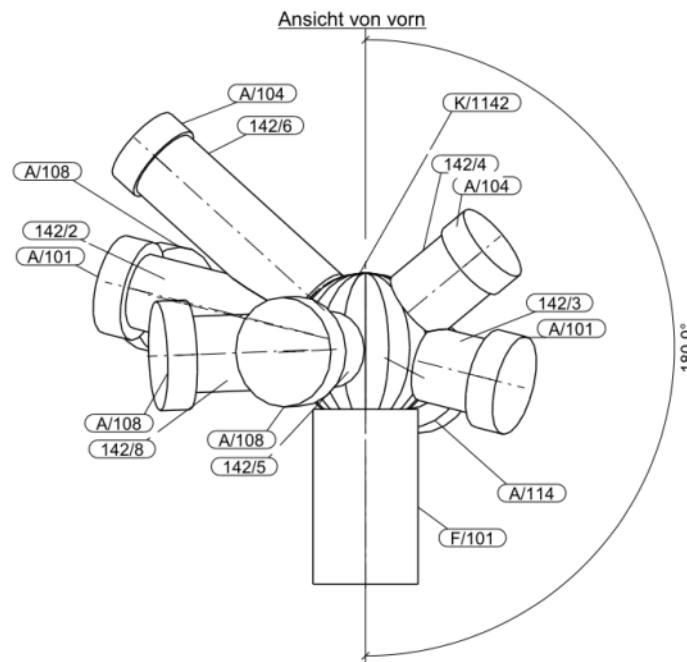



## 2. Structure description

- The exterior sides of the structure are covered with Atex™ membranes (coated glass textiles) which are weatherproof, hydrophobic and dimensionally stable.
- The membranes are connected with the main structure by special piping (keder) profiles.
- The membranes are pre-tensioned.

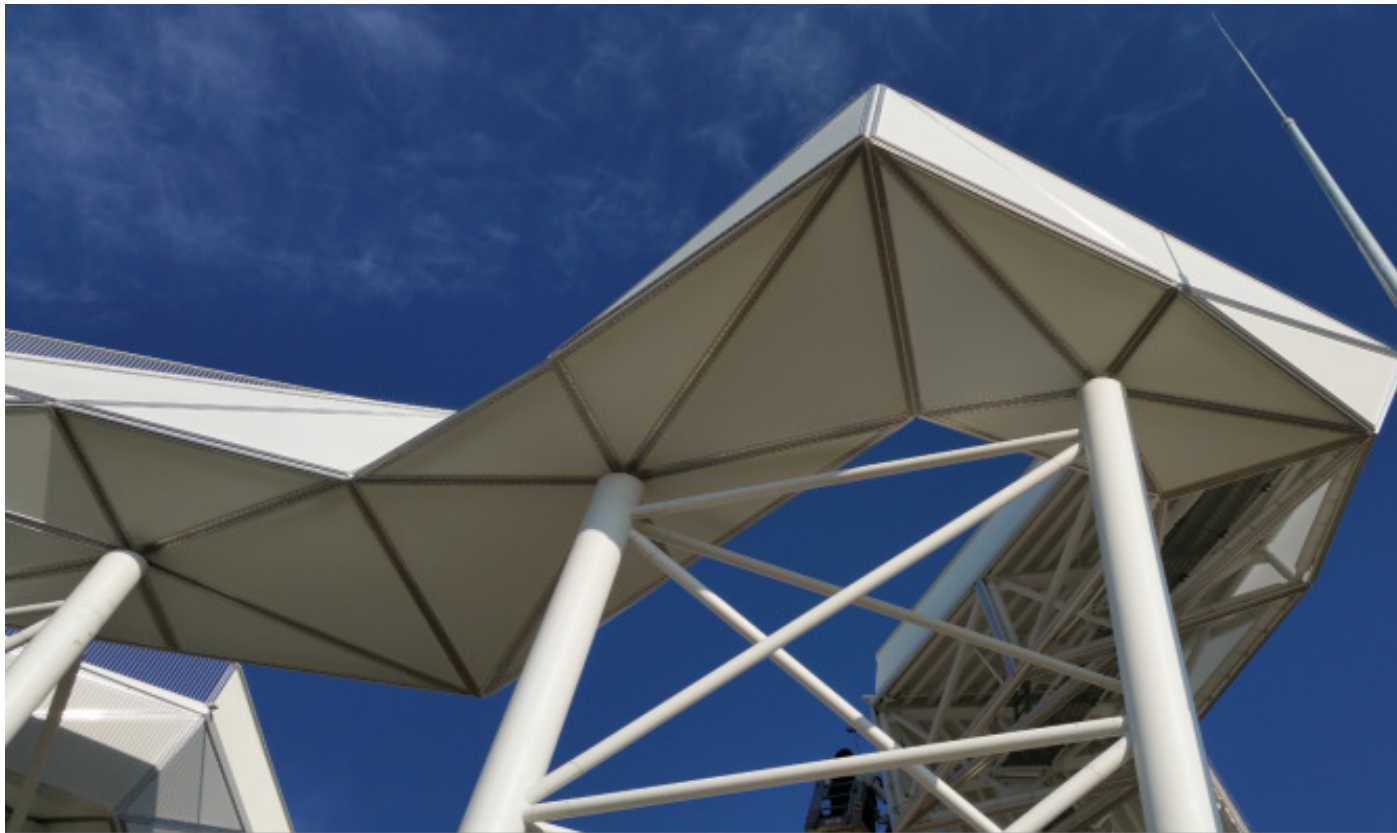

## 2. Structure description

The “Wolkenhain” is equipped with an interior lighting system





### 3. Design procedure

- For the purpose of the check calculations a three-dimensional framework model was created using the computer program Sofistik.
- All parts of the structure, except solid steel balls, could be modeled with their exact geometry.

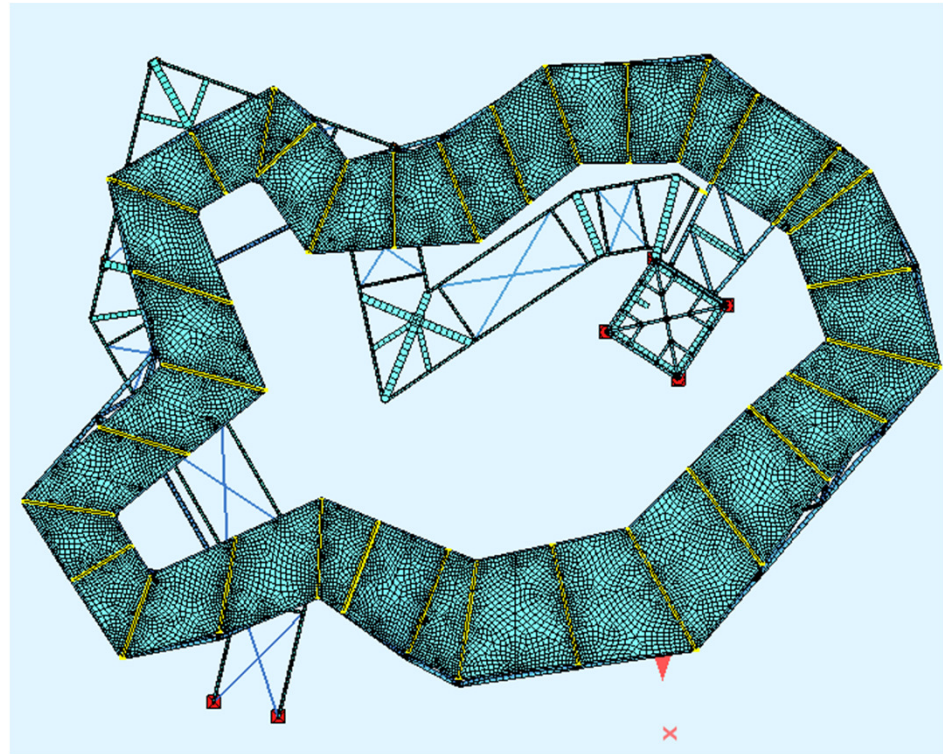
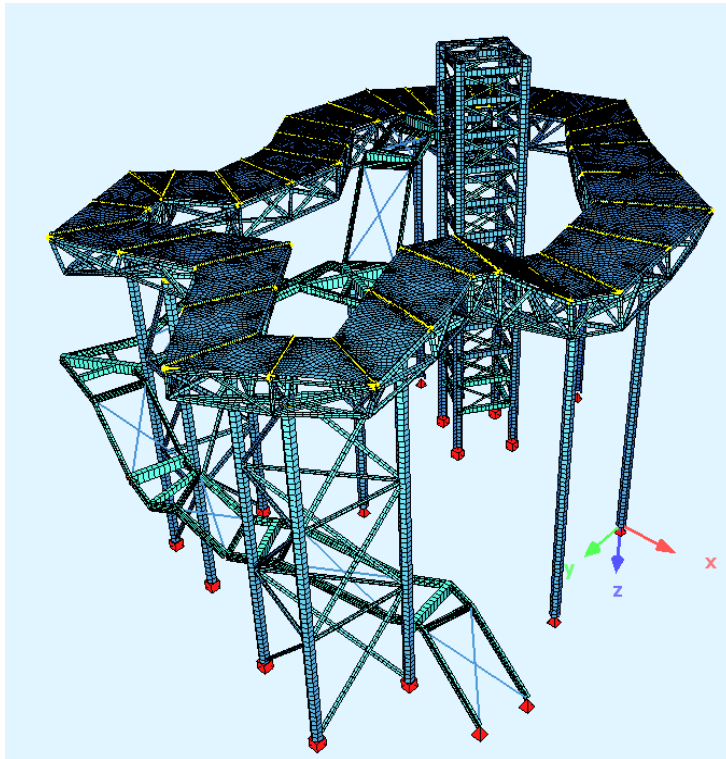

### 3. Design procedure

- Due to complexity it was not possible, to define the membrane in the computer model.
- The membrane were calculated separately.
- On this way the local loads for the bars of the structure were defined.
- Finally, the loads resulting from the membranes were superimposed with the global ones

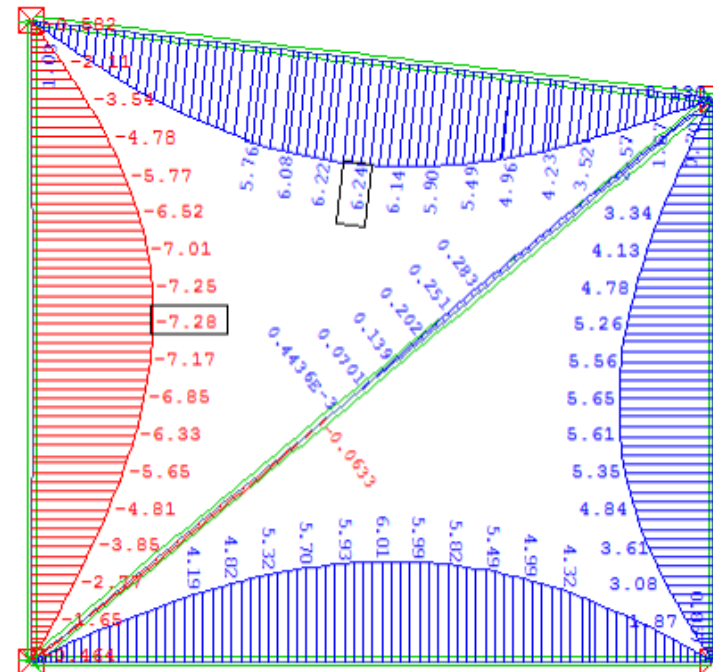
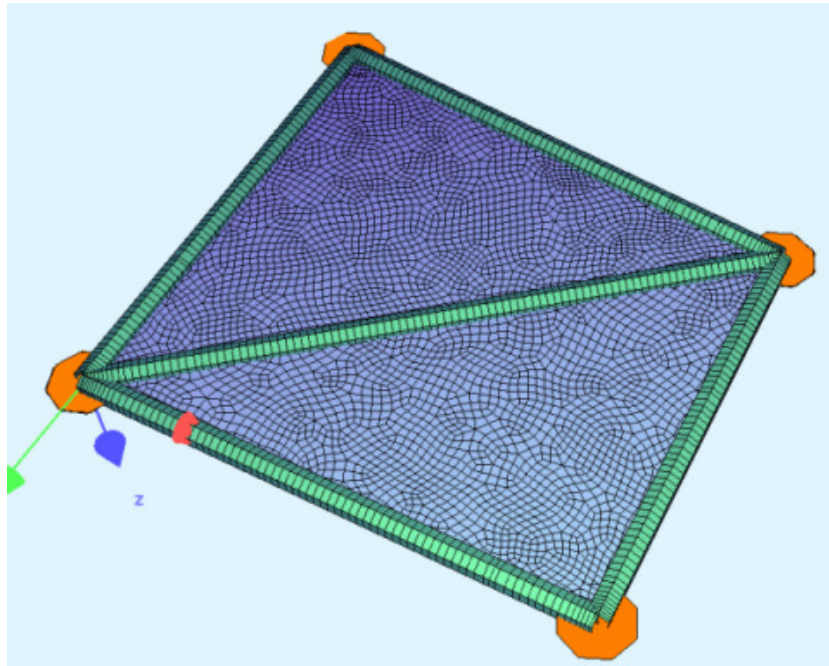



### 3. Design procedure

#### Calculation assumptions

- The structure was designed as a footbridge in accordance with DIN EN 1991-2
- The structure was calculated for following loads:
  - a) dead loads: The dead loads of all frame members have been considered within the computer model. The other dead loads (solid steel balls, textile membrane with its components) had to be considered as additional dead-load.
  - b) pedestrian load (5 kN/m<sup>2</sup>)
  - c) wind loads
  - d) temperature loads

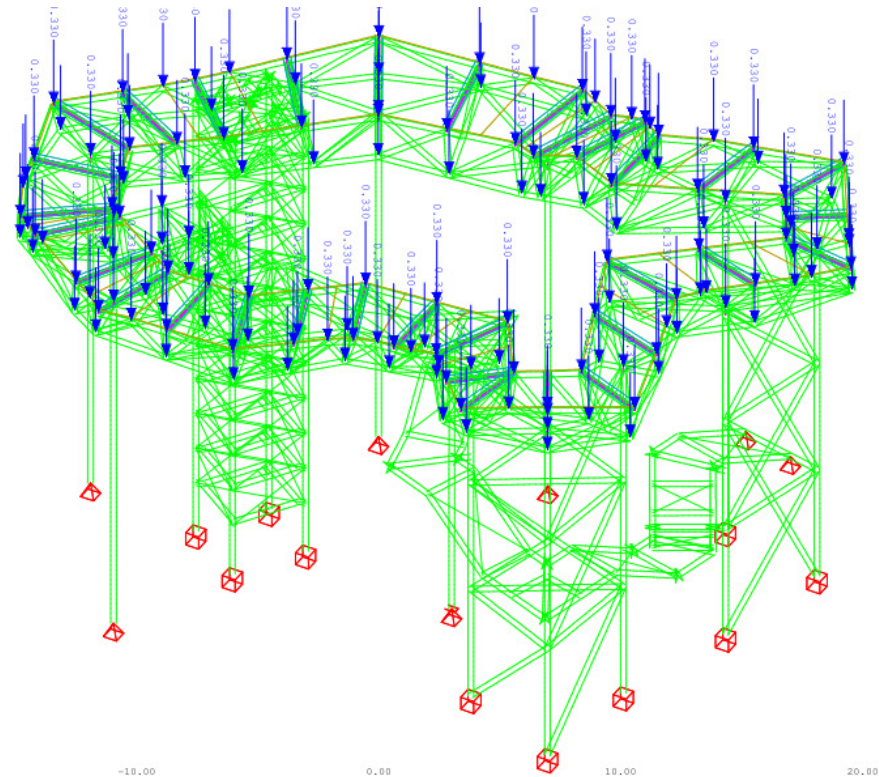

### 3. Design procedure

#### Wind load

- Because of the complicated shape of the structure the rules of DIN EN 1991-1-4 could not be used for calculating the wind load.
- The checking engineer suggested a survey of the local wind velocities and wind forces by a wind load expert.
- The wind survey defined:
  - a) the influence of the topography of the construction site,
  - b) the wind load at the bottom side of the structure
  - c) the pressure inside the structure.

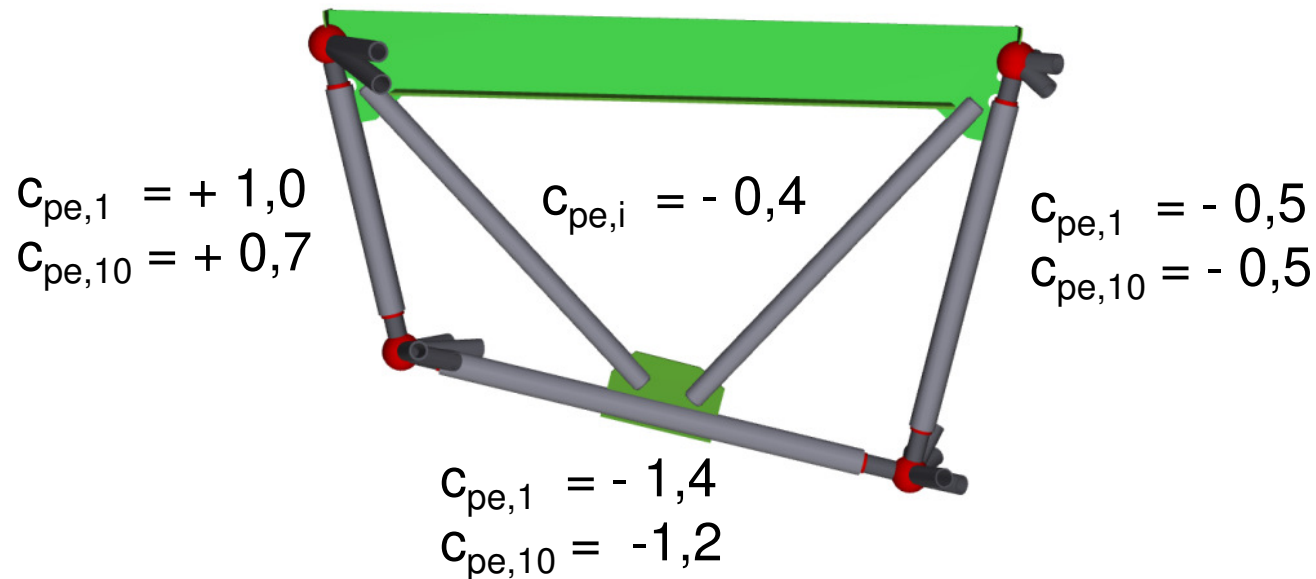



### 3. Design procedure

#### Dynamic influences

- It is well known, that the natural frequencies of such kind of structures as "Wolkenhain" are very low.
- It is necessary to investigate the dynamic response due to wind loads.
- The checking engineer strongly recommended to investigate this problem.
- With the cooperation of the wind load expert this task was solved.
- The first natural frequency of the structure is about 1,91 Hz and with this was proved that the value of the equivalent static wind load has not to be increased significantly.

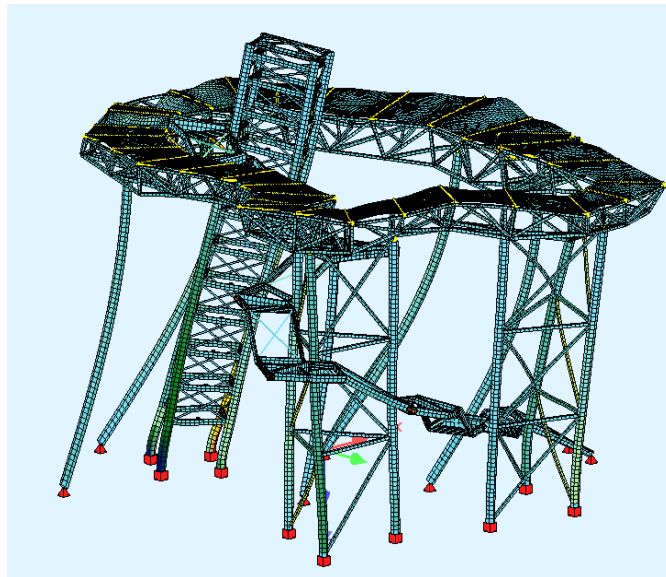

First neutral frequency  $f_1 = 1,91$  Hz

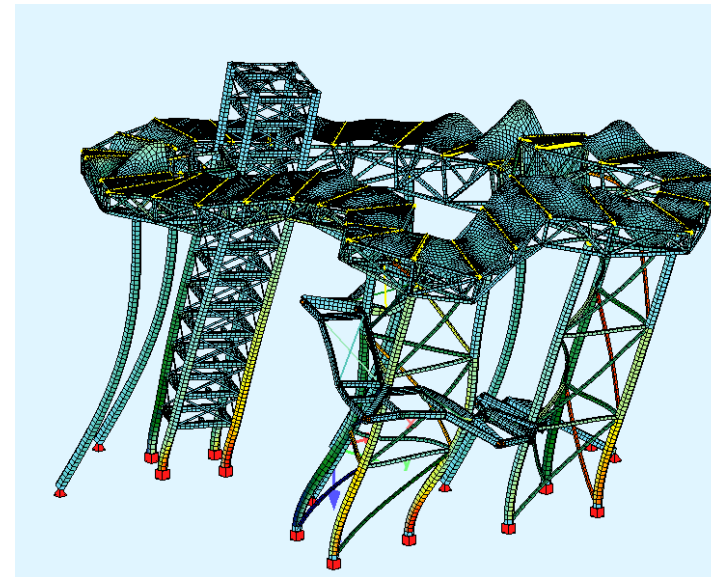

Second neutral frequency  $f_2 = 2,69$  Hz

### 3. Design procedure

#### Calculation procedure

- The stability calculation of the members of the structure had to be done according to the theory of second order with initial local imperfections  $e_0$  in accordance with DIN EN 1993-1-1.
- Hereby an optimization of cross-sections of framework took place.
- For each bar the stresses were calculated in three different sections of the bar.
- The global normal forces  $N$  were superimposed with bending and torsion moments  $M$  and the shear forces  $V$  resulting from the membrane load  $q$ . In general the membrane loads acted in two directions and they also had to be superimposed.

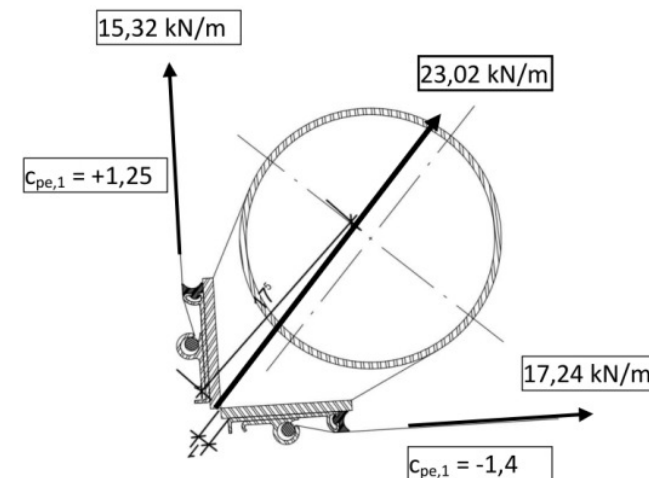
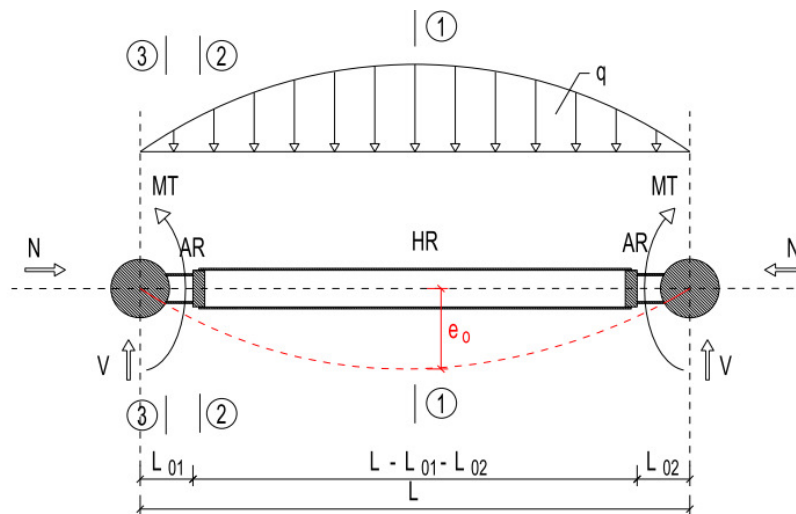



## 4. Design of Connections

### Joint description

- All bars of the spatial truss were connected with the solid steel balls.
- About 160 such connections were needed to build the structure.
- Every ball has a diameter of 200 mm and was produced from steel S355 J2+N.
- In case of some connections even 8 bars were joined with one ball.



## 4. Design of Connections

### Welding tests

- Due to the vital importance of the balls for the structural safety the checking engineer advised to prove the quality of the material and the welded connections.
- Due to the connection with a number of bars a spatial state of stress arises in the balls.
- The huge number of welds and their difficult geometries leads to additional residual stresses, which overlays the spatial stresses.
- It was important to know if these stresses can be absorbed.

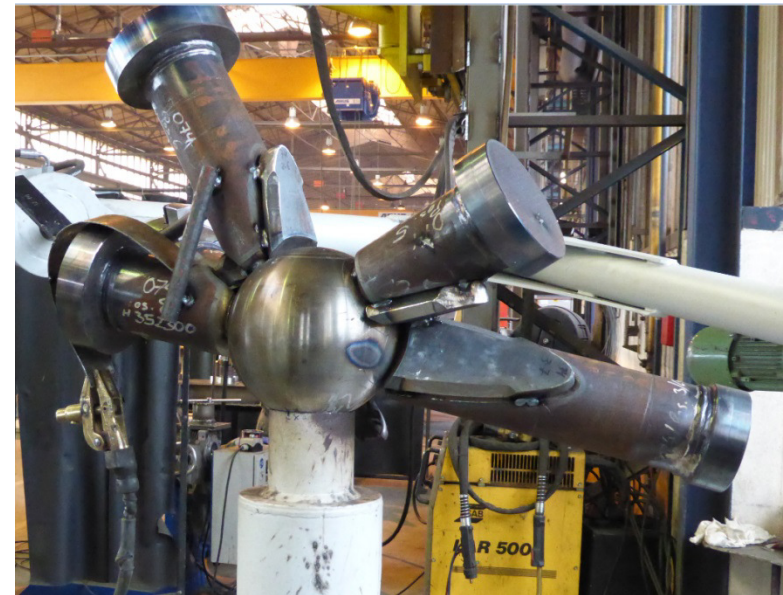
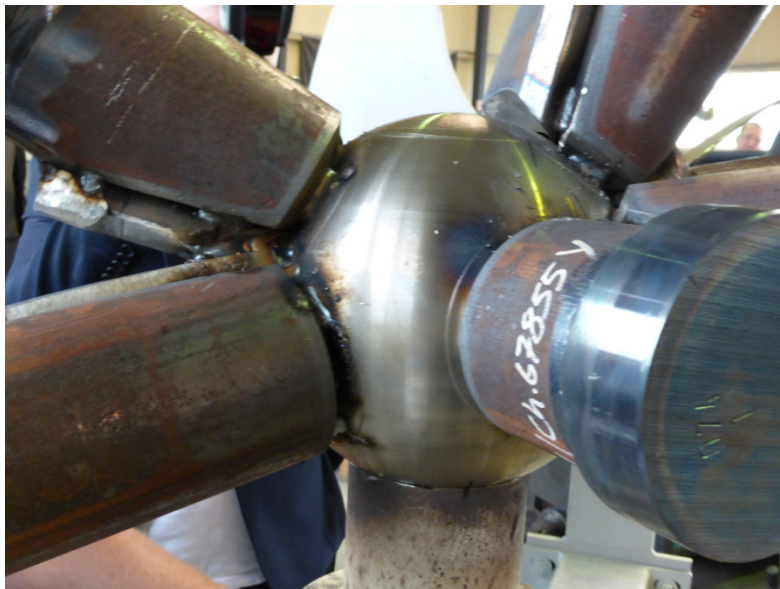

## 4. Design of Connections

### Welding tests

- Several experimental tests of the material and connections were conducted by the institute for welding technology GSI SLV Halle.
- The tests showed that the welding parameters, chosen by the manufacturing company, led in some cases to insufficient quality of the welds, which could cause the malfunction of the connections.
- These parameters had to be unconditionally improved.

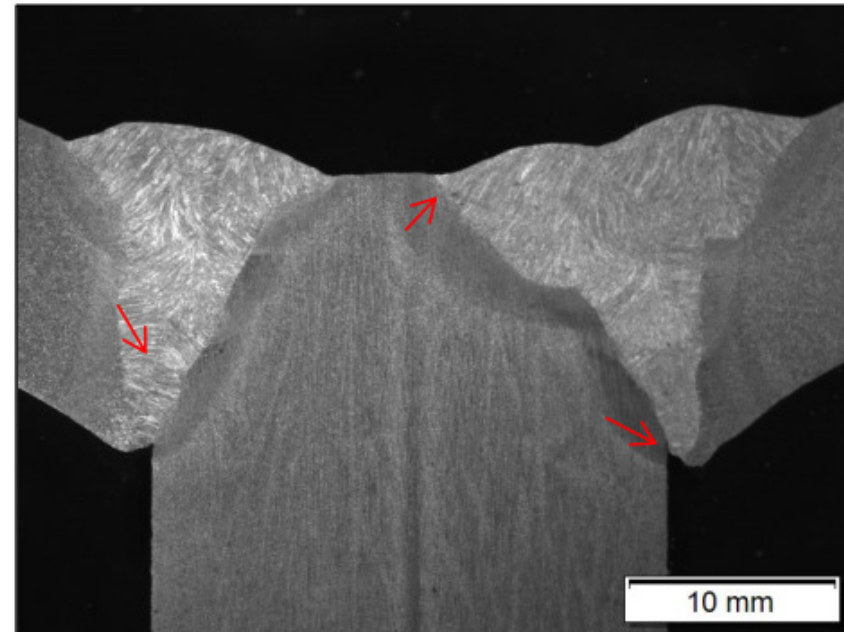
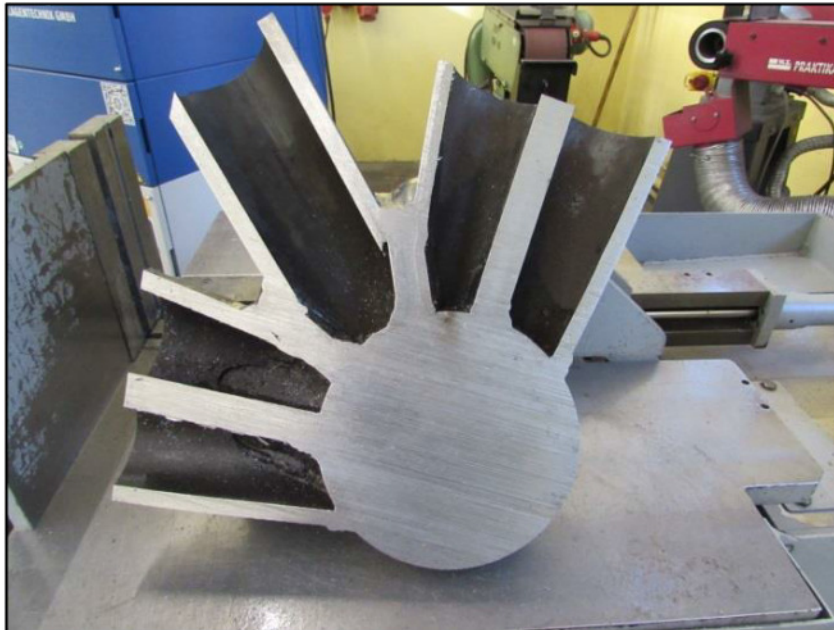



## 4. Design of Connections

### Welding tests

- For this purpose, GSI SLV prepared new welding specifications (WPS) with improved welding parameters.
- With the use of those parameters it was possible to weld the joints with sufficient quality and to ensure the required bearing capacity of the structure.



## 5. Manufacturing and assembly of the structure

### Workshop planning

- The very irregular geometry of the structure required an extensive workshop planning which was made with the computer program Tekla.
- The check of workshop drawings took place by the direct check of the electronic model from that program.

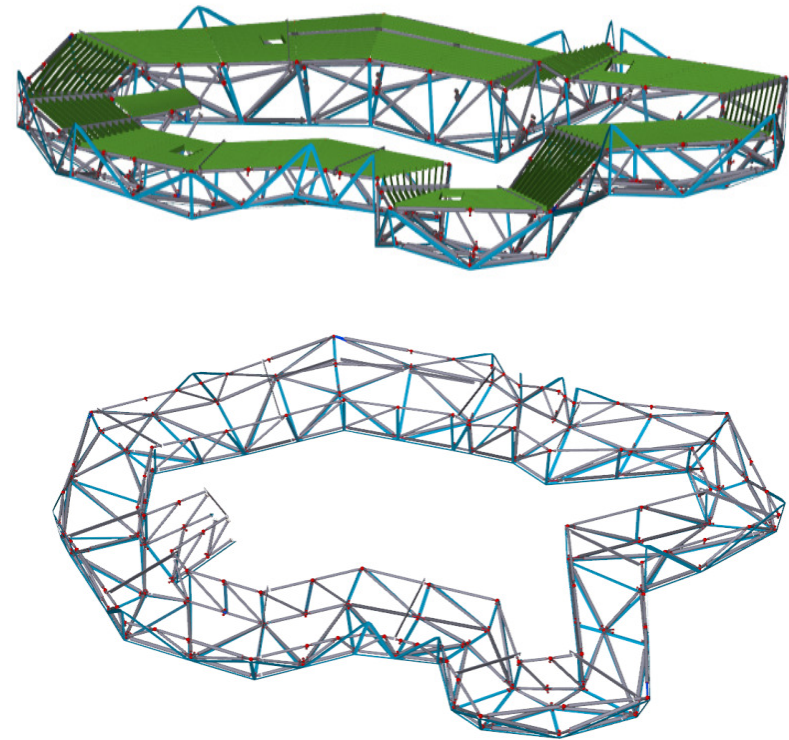
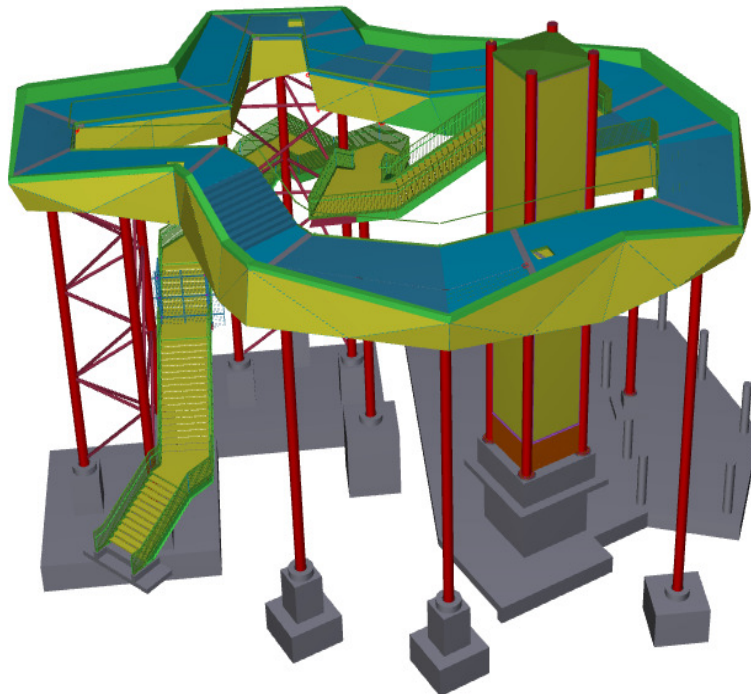

## 5. Manufacturing and assembly of the structure

### Manufacturing in workshop

- The structure was manufactured by the steel construction company Vollack GmbH.
- The manufacturing process had two steps.
  - a) At first all the joints were welded and then they were connected with other bars of the structure to an segment . All in all 14 segments were produced.
  - b) After that the clamp profiles for the membranes were welded to the members of the segments.





## 5. Manufacturing and assembly of the structure

### Assembly

- For manufacturing and assembly reasons the structure was divided into 14 sections.
- Every section consists of connected transverse frames, a part of the deck and the substructure for the pretensioned membranes.
- The sections of the structure were delivered to the construction site and finally assembled.

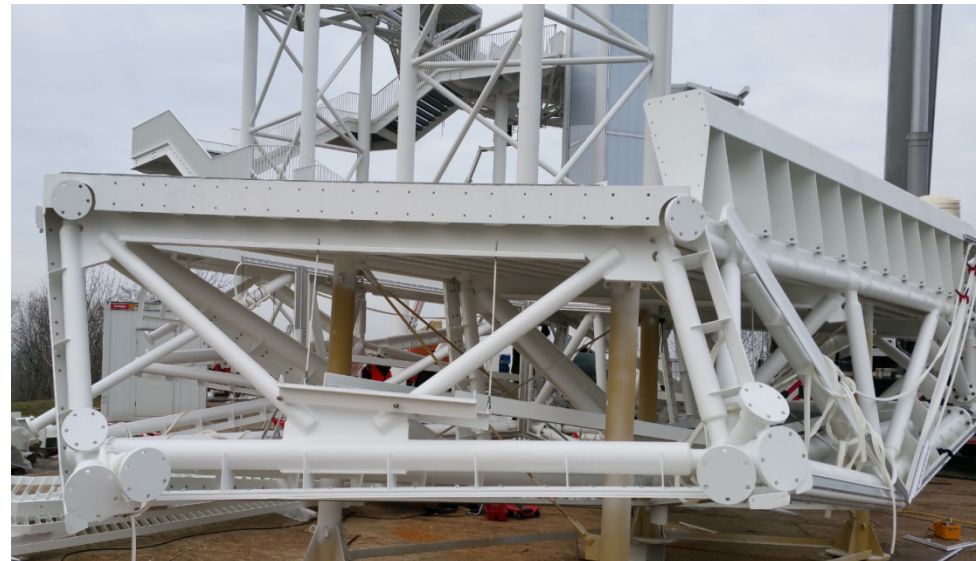
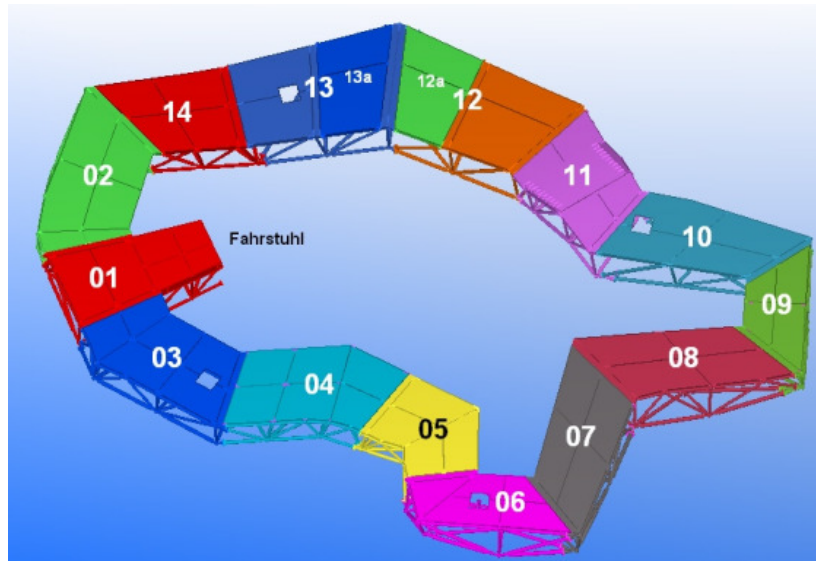

## 5. Manufacturing and assembly of the structure

### Assembly

- In a first step the steel columns and the elevator tower were mounted.
- In a second step, particular sections were joined together in so called assembly groups and then built-in.





## 5. Manufacturing and assembly of the structure

### Assembly

- Further assembly groups were built-in.

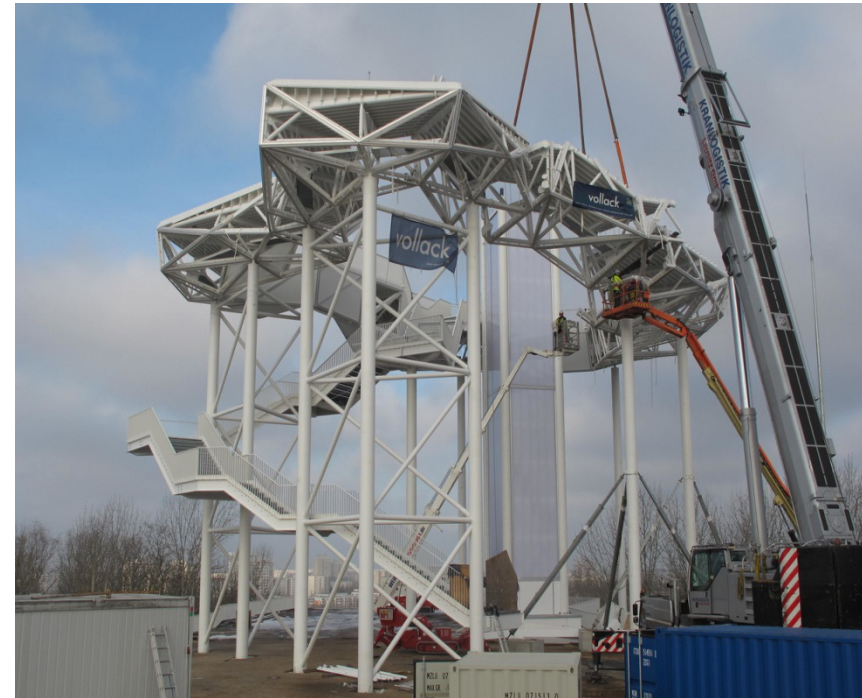
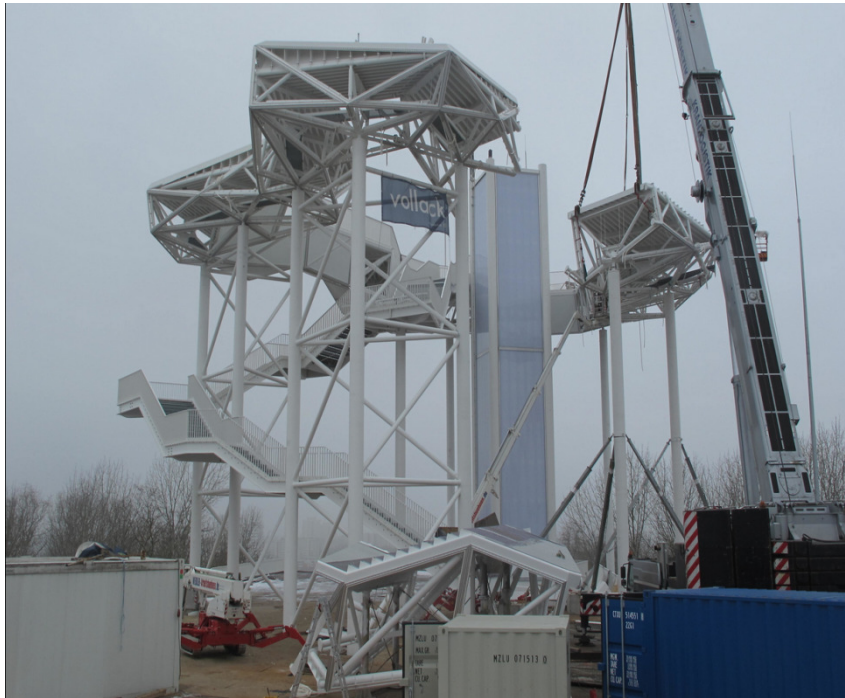



## 5. Manufacturing and assembly of the structure

### Assembly

- By reason of piecewise assembly numerous different static systems arised. It was necessary to check these different static systems of the structure.
- In every case it was proved that the structure has sufficient capacity and stability.

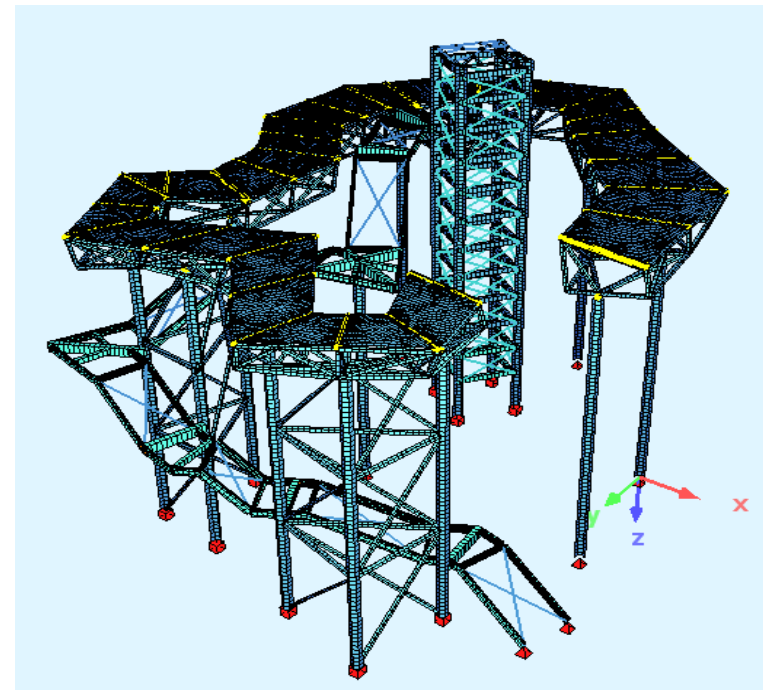

## 5. Manufacturing and assembly of the structure

### Completed structure

- After the completion of the main supporting structure the membrane were assembled.



## 6. Discussion and Conclusions

### Main Conclusions

- The checking calculations showed, that during the design process of constructions like the “Wolkenhain”, many additional aspects have to be considered.
- In case of wind load it was necessary to take advantage from the cooperation with the wind experts in order to find appropriate assumptions for wind loads and dynamic approach.
- The rules of DIN EN 1991-1- 4 (wind loads) can be used only for designing typical constructions.
- Moreover, it is strongly recommended that welded joints with very complicated geometries should always be experimentally checked to guarantee the safety of the structure.
- The manufacturing process of complicated structures should be supervised.
- Thank to the cooperation between structural and checking engineers as well as wind and welding experts. Thereby it was possible to create and to build this amazing structure.



## 6. Discussion and Conclusions

### Acknowledgements

We thank:

KOLB RIPKE ARCHITEKTEN



The logo for 'vollack' consists of the word 'vollack' in a lowercase, blue, sans-serif font, centered within a light blue rectangular box with a thin dark blue border.

for assistance by the writing of this paper.

## 7. Views

### Invitation to IGA

13. April 2017 bis 15. Oktober 2017

Ein **MEHR**  
aus Farben  
An *OCEAN* of colours

**IGA  
BERLIN  
2017**  
INTERNATIONALE  
GÄRTEN  
AUSSTELLUNG

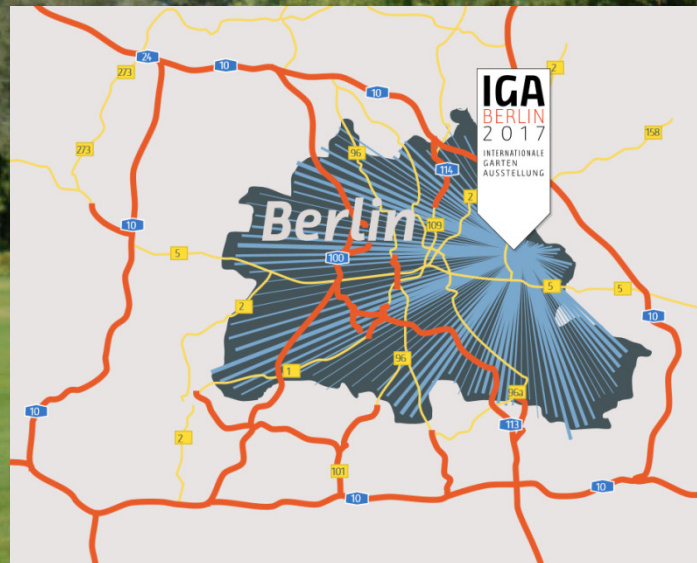





*Thank you  
for your attention*